

OBS 1. ABERTURAS INTERNAS E EXTERNAS COR CINZA

OBS 2. TODOS OS SANITÁRIOS DEVEM SER SINALIZADOS COM O SÍMBOLO REPRESENTATIVO DE SANITÁRIO

OBS 3. MEDIDAS SANITÁRIO ACESSÍVEL NBR 9050 /2020

OBS 4. SINALIZAÇÃO PAREDES DE VIDRO NBR 9050 /2020

ABERTURAS		QUANT.	DESCRIÇÃO	P05-P09	P04	P01-P02-P07-P08	P03	P06
REF.	DIMENSÃO							
P01	0,90x2,10M	02	MADERA/SEMOCA/ABRIR-01 FOLHA					
P02	0,70x2,10M	04	MADERA/SEMOCA/ABRIR-01 FOLHA					
P03	1,40x2,10M	01	MADERA/SEMOCA/VIDRO/ABRIR-02 FOLHAS					
P04	0,80x2,10M	06	MADERA/SEMOCA/VIDRO/ABRIR-01 FOLHA					
P05	1,80x2,20M	01	MADERA/MACCA/VIDRO/ABRIR-02 FOLHAS					
P06	3,10x2,20M	01	MADERA/MACCA/VIDRO/ABRIR-02 FOLHAS					
P07	0,80x2,10M	04	MADERA/MACCA/VIDRO/ABRIR-01 FOLHA					
P08	0,80x2,10M	01	MADERA/MACCA/VIDRO/ABRIR-02 FOLHAS					
P09	1,70x2,10M	01	MADERA/MACCA/VIDRO/ABRIR-02 FOLHAS					

ABERTURAS		QUANT.	DESCRIÇÃO	J01	J02	J03	J04-J05	J06
REF.	DIMENSÃO							
J01	2,00x1,30x0,90M	26	MADERA/MACCA/VIDRO/JANELA DUPLA DE GULHOTINA SIMPLES 04 FOLHAS					
J02	1,00x0,50x1,70M	08	MADERA/MACCA/VIDRO/OSCILANTE SIMPLES 01 FOLHAS					
J03	1,00x1,30x0,90M	04	MADERA/MACCA/VIDRO/JANELA SIMPLES DE GULHOTINA SIMPLES 02 FOLHAS					
J04	1,70x1,50x0,90M	01	MADERA/VIDRO/FIXO 01 FOLHA					
J05	2,75x1,50x0,90M	04	MADERA/VIDRO/FIXO 01 FOLHA					
J06	4,00x3,45 M	01	VIDRO/FIXO NO PISO E TETO ESP. 10MM					

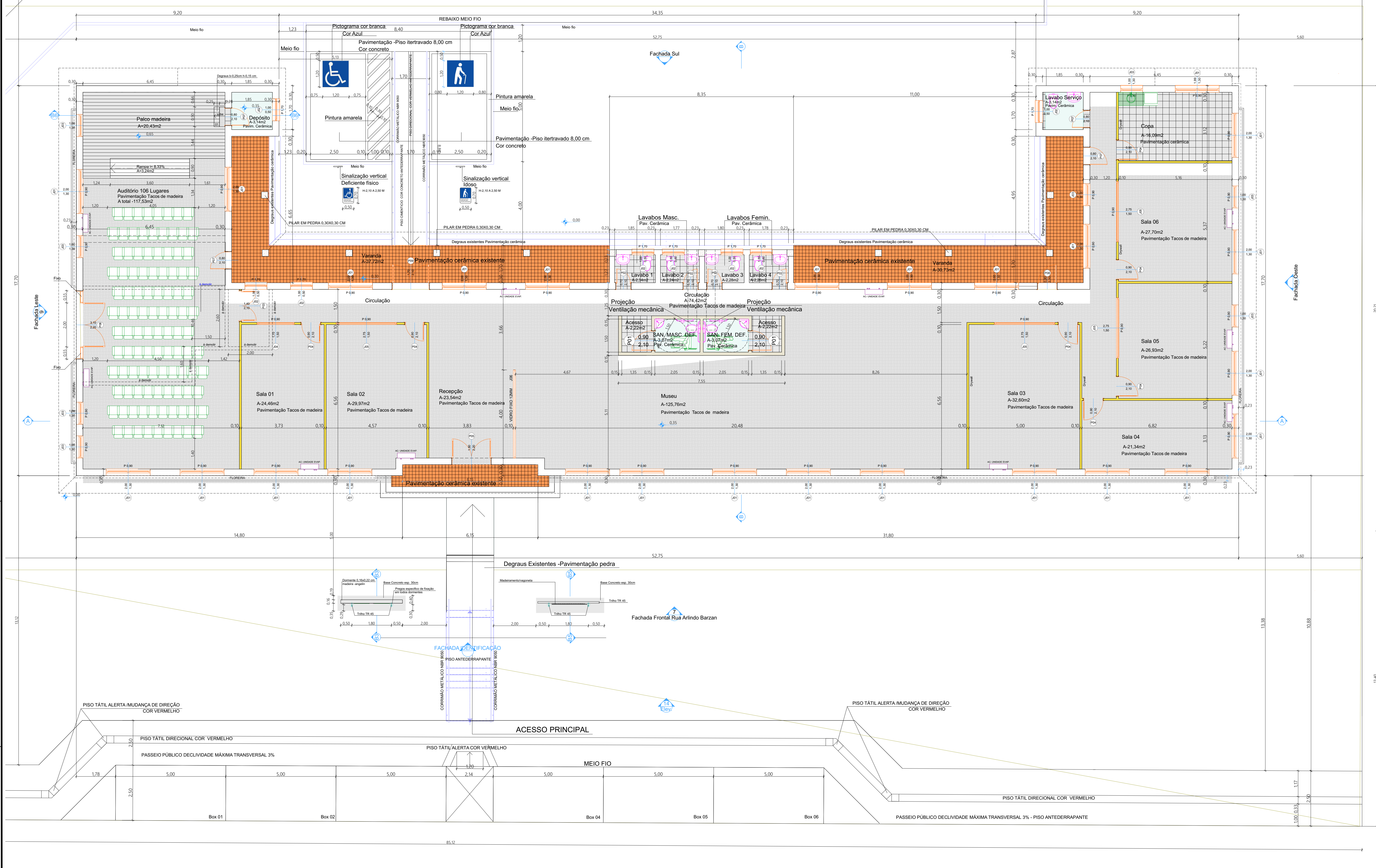
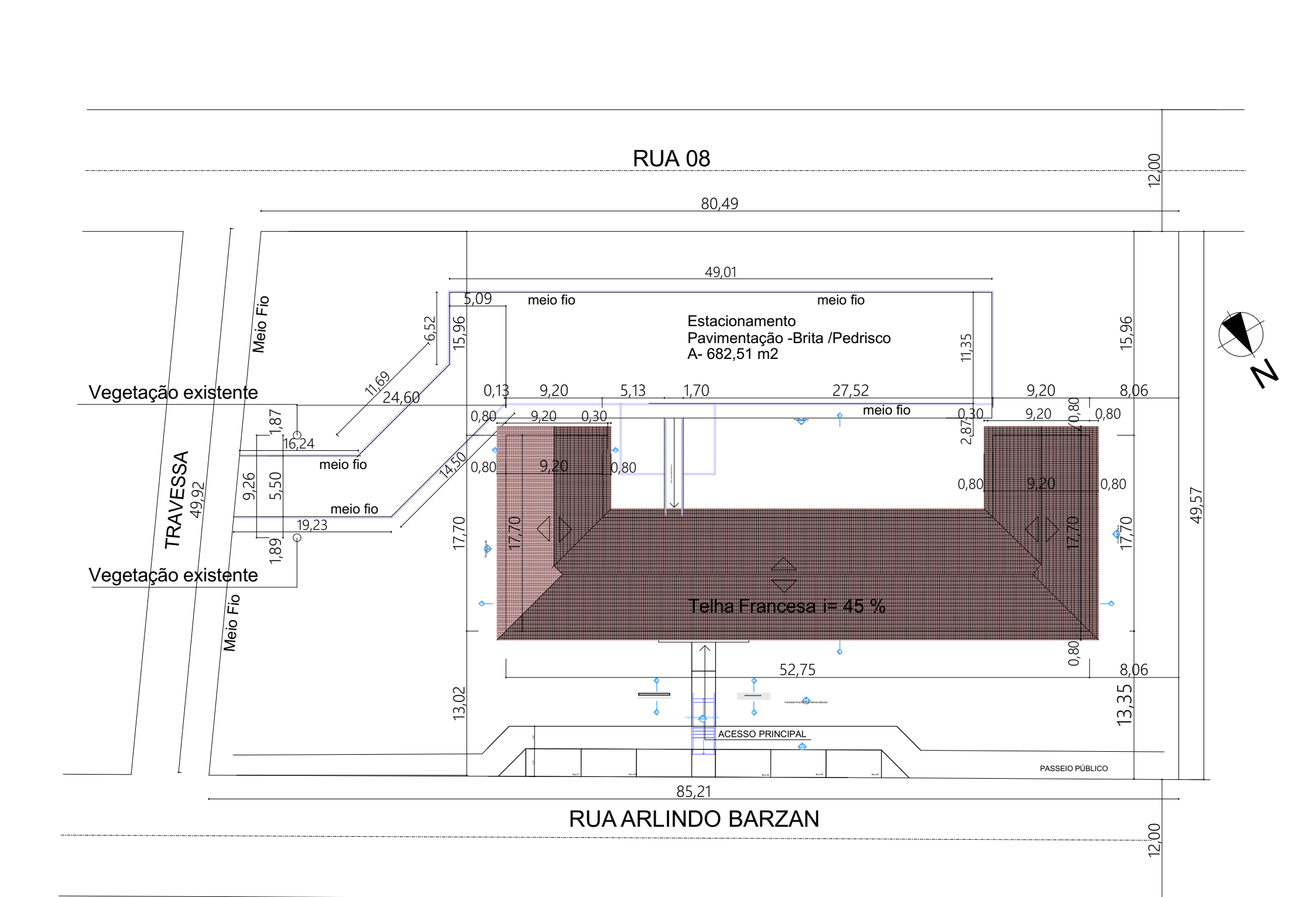
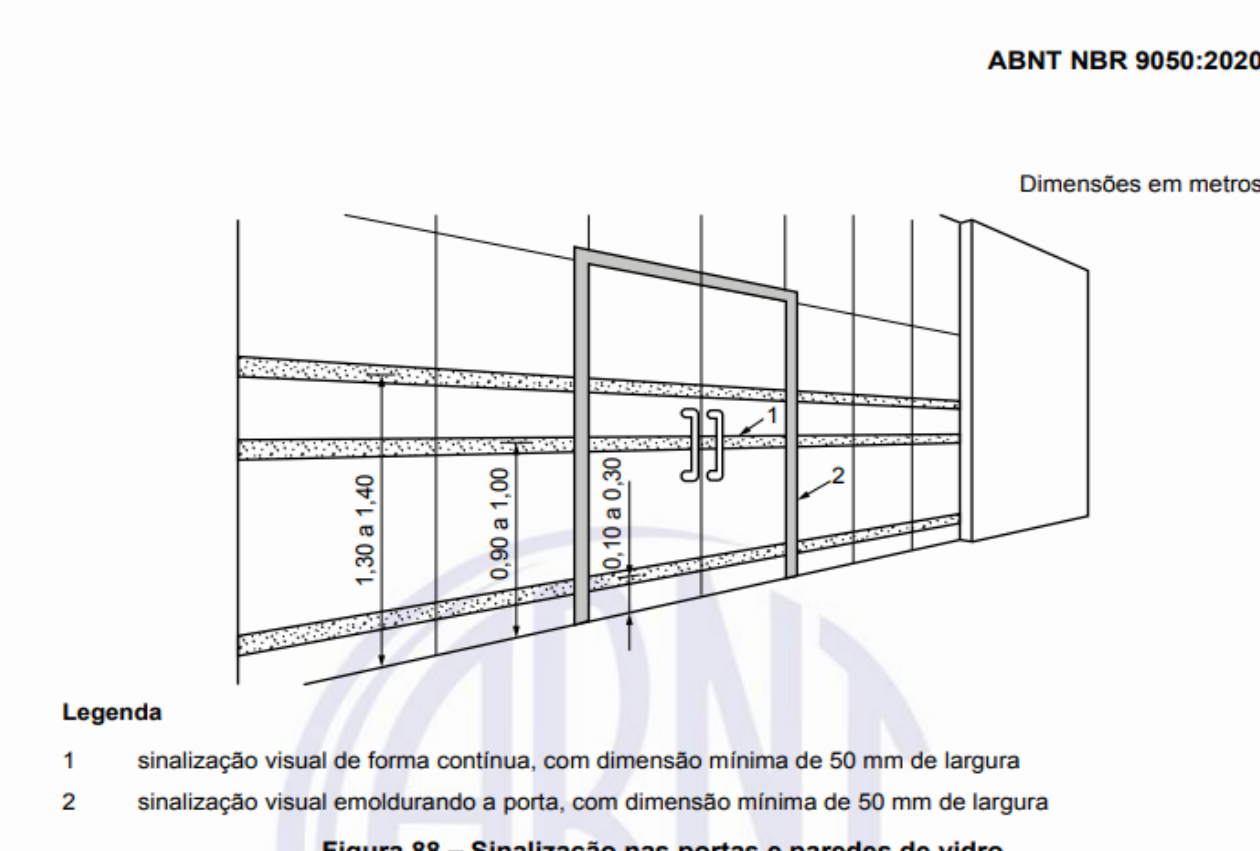
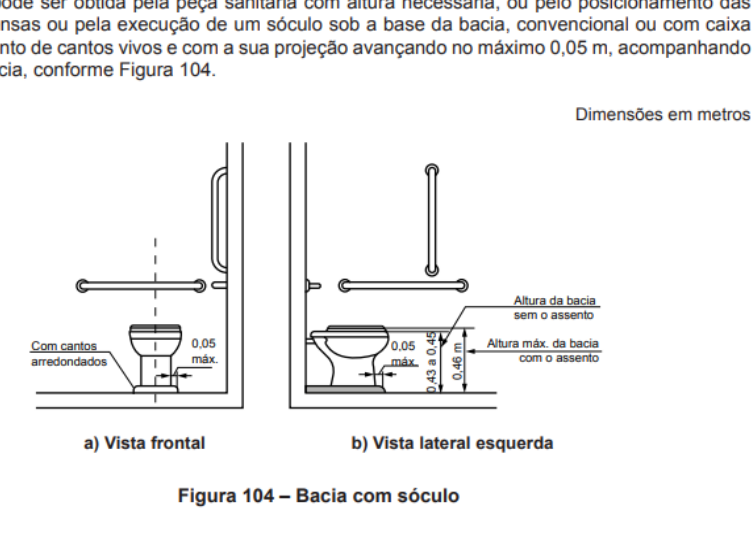
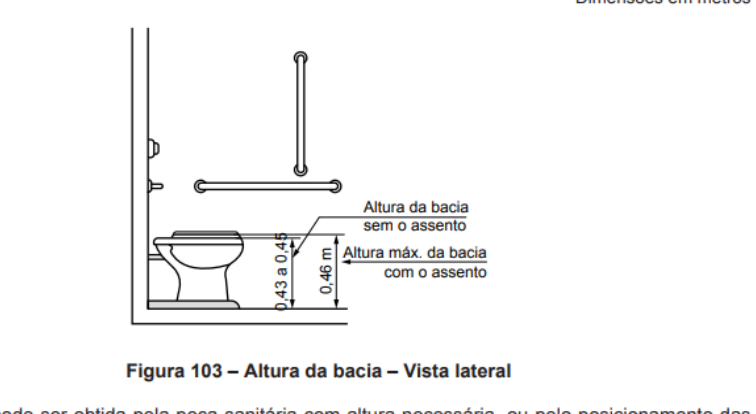
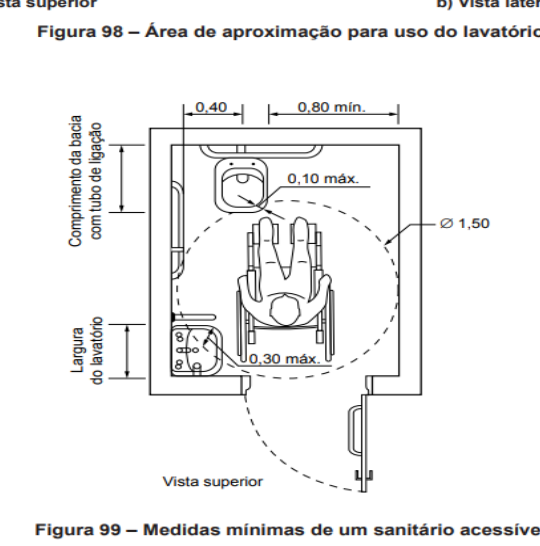
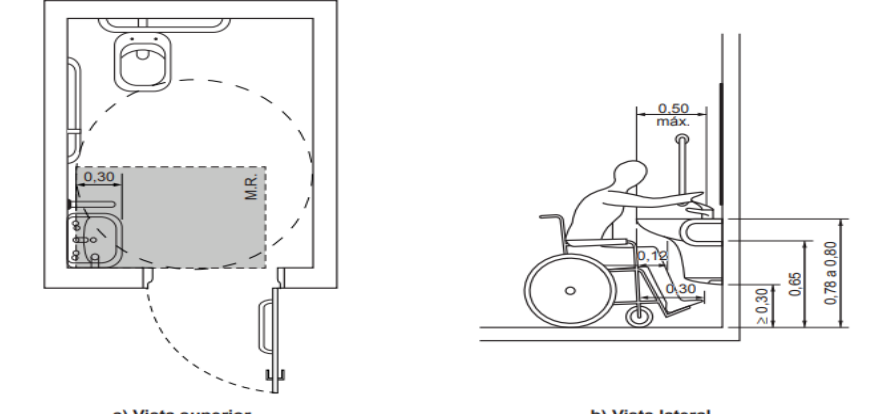

PLANTA BAIXA ESCRITÓRIO C.S.N. A. TOTAL - 674,85 M² 1:75

ALVENARIA EXISTENTE
 A CONSTRUIR-BLOCO ESTRUTURAL
 DIVISÓRIA / GESSO ACARTONADO
 ALVENARIA A DEMOLIR

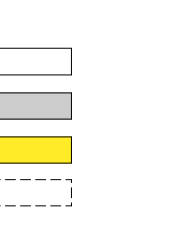

PROJETO
REFORMA ANTIGO ESCRITÓRIO C.S.N.

ENDEREÇO
 RUA ARLINDO BARZAN

BARRIO
 RIO FLÓRTIA

CIDADE
 SIDERÓPOLIS

ESTADO
 SANTA CATARINA

CLIENTE
 PREFEITURA MUNICIPAL DE SIDERÓPOLIS

ARQUITETO E URBANISTA
 CLEBER ANTONIO ZANELLATTO

DATA
 18/03/2022

ÁREA
 674,85 M²

FOLHA
 02/03